

Manifold Gas Flow Controller/meter Operating Instructions

1. product description

1.1 Uses and features

Mass Flow Controller(MFC)Used to accurately measure and control the mass flow of gas. They play an important role in scientific research and production in various fields such as semiconductors and integrated circuit industries, special materials disciplines, chemical industry, and industrial, pharmaceutical, environmental protection, and vacuum lamps. Typical applications include: electronic process equipment such as diffusion, epitaxy, CVD, oxidation, plasma etching, sputtering, and ion implantation; and coating equipment, optical fiber smelting, microreaction devices, mixed gas distribution systems, capillary measurement, Gas chromatographs and other analytical instruments

1.2 Main Specifications

1	Flow range:	(0~5, 10,20,30,50,100,200,300,500...) SCCM (0~1,2,3,5,10,50,100,200,500...) SLM
2	Accuracy	±1%F.S ±0.5%F.S
3	Linearity	±0.5~1.5%F.S
4	Repeatability	±0.2%F.S
5	Responding time	Electrical characteristics:10sec gas characteristics : (1~4) sec
6	Differential pressure range	0.1~0.5MPa
7	Max pressure	3MPa
8	Working temperature	0~70℃
9	Digital value	RS485 MODBUS
10	Analog value	DC 0~5V , 4~20mA
11	Power supply	DC +15V/24V, flow meter<400mA, flow controller< 600mA
12	Electrical connection	DB15
13	Leakage rate	1×10^{-8} SCCSHe
14	Material of base	316L Stainless steel
15	Seal material	FKM, nitrile butadiene rubber, chloroprene rubber
16	Glad hand	Φ3, Φ6, Φ10, 1/8" ,1/4" , 3/8"

note:

The mass flow meter and mass flow controller are usually calibrated with nitrogen (N2).

The unit of mass flow is stipulated as: SCCM (Standard ml/min); SLM(Standard l/min)

Standard state stipulates: temperature -----273.15K (0℃);

Pressure -----101325 Pa(760mm Hg)

F.S (Full Scale);

Full-scale value

1.3 Working principle

The excellent accuracy, robustness and reliability of the CX series gas mass flow controllers stem from our unique sensor probes. The sealed probe consists of two sensing elements - speed sensor and temperature sensor, which can automatically correct the influence caused by the change of temperature and pressure. The meter circuit heats the speed sensor to a constant value higher than the gas temperature, and then measures the cooling effect of the gas flow. The flow is calculated under the principle that measuring electric power consumed which used to maintain a constant temperature difference, which is proportional to the mass flow of the gas. Both sensors are standard platinum resistance temperature detectors (RTD). Platinum RTD wire is wrapped around a solid ceramic core, firm and reliable. The entire sensor is sealed in a 316 stainless steel packing case.

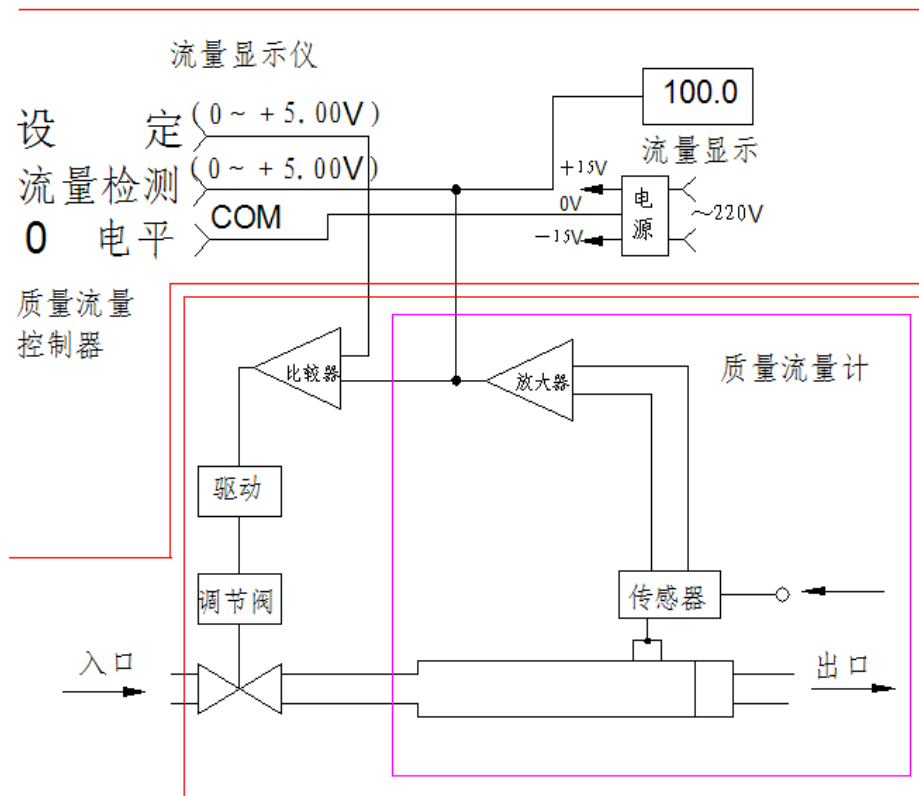

Picture(3)Working principle diagram

2. Quick installation guidance

2.1 Shape and installation dimensions

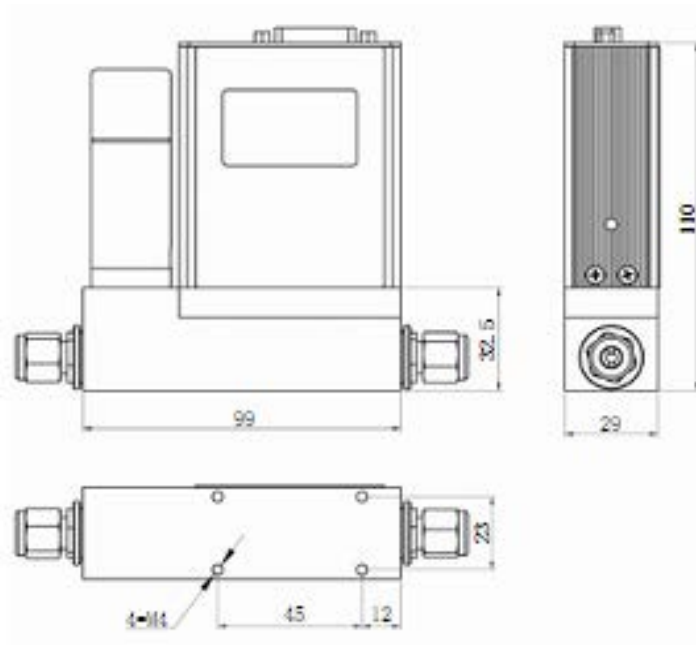

图三、CX Dimensions of mass flow controller

2.2 Form of gladhand

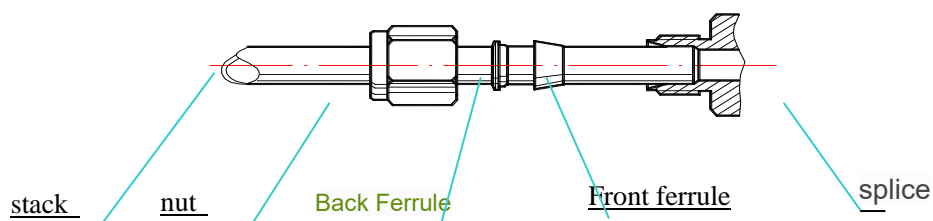

Picture(4)Installation diagram of double ferrule splice

As shown in picture 4, when installing the splice, after installing the front ferrule, back ferrule, and nut, tighten the nut and the splice by hand, then tighten with a wrench (The imported Swagelok splice requires a 1.25-turn wrench to tighten.) to ensure air tightness. Note that double wrench should be used, with one wrench stuck in the joint and the other to turn the nut. Especially when removing the nozzle, double wrench must be used, otherwise it will cause loosening of the joint and affect the sealing.

2.3 Cable connection plug

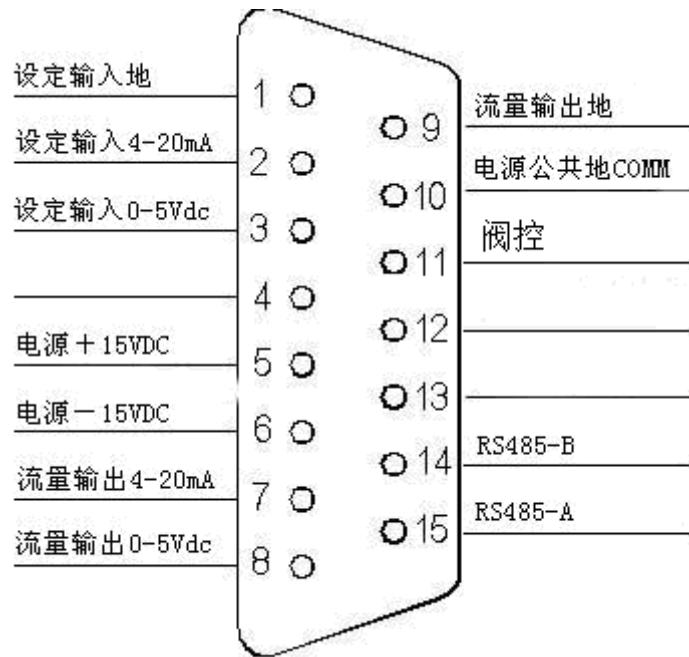

Picture(5) ±15VDC Power supply diagram

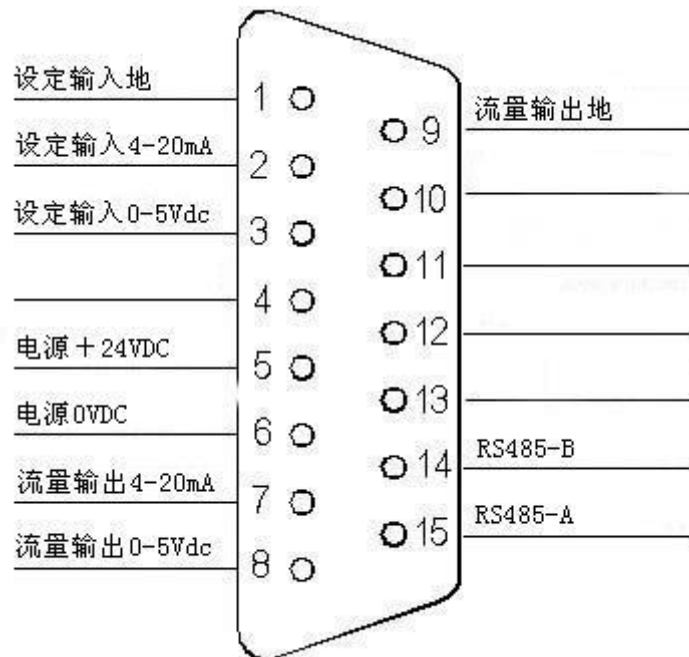

Picture(6) 24VDC Power supply diagram

3. Functional operation details

3.1 Review

The CX series flow meter uses a backlight lattice liquid crystal display, which clearly displays a variety of useful flow data, including instantaneous flow, accumulative flow, temperature, etc. CX has different display screen, it depends on the type of the order, such as flow meter or controller, current output or voltage output. The entire CX series has a unified main display screen, gas selection screen (which may be invalid when certain gases are present), calibration screen, device information, etc.

In the state of the main screen condition, press the [MENU] button on the lower right corner of the flow meter to switch the display screen to the menu screen.

3.2 Common operation

Interface specification

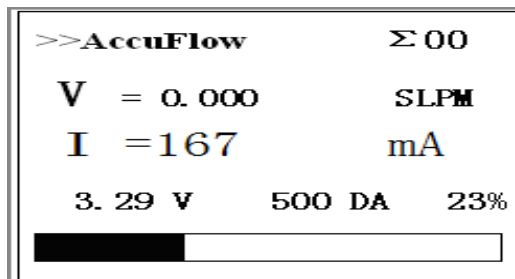

picture 1 Monitoring value display status.

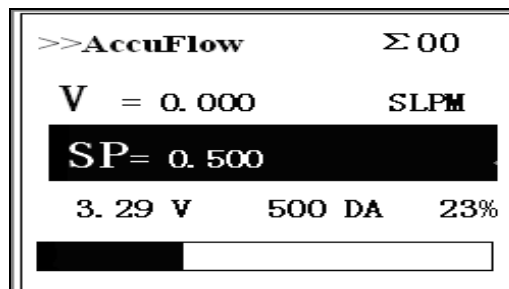

Picture 2 Valve control setting status

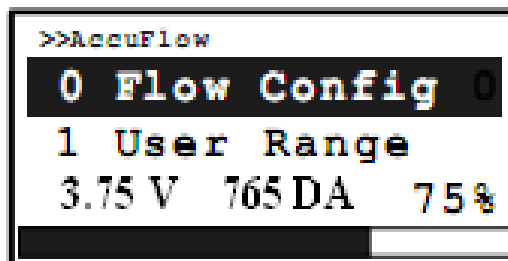

Picture 3 Menu display status

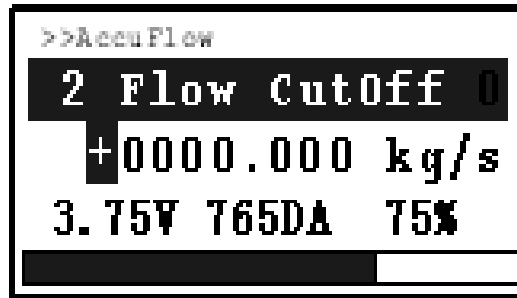

Picture 4 Parameter input dialog box

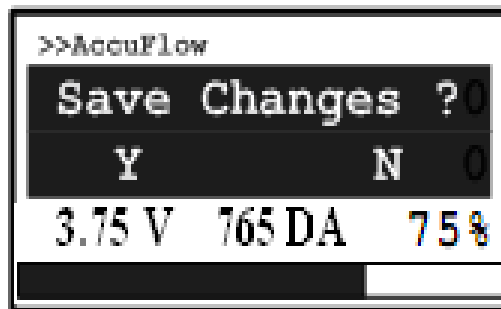

Picture 5 Storage inquiry dialog box

The function of the keys in different display situations:

[Monitoring value display status]:

Press **[Left]** key to switch current display parameters in sequence: instantaneous flow, current, medium temperature, accumulated flow, etc.

Press the **[Right]** key to reverse the current display parameters in order: cumulative flow, medium temperature, current, instantaneous flow, etc.

Press **[MENU/OK]** to enter the MENU display status.

[Menu display status]:

Press the **[Right]** key to switch the menu items of the current menu in sequence.

Press **[left]** key to return to the previous menu.

Press the **[MENU/OK]** key to enter the next menu or the parameter input dialog box].

[Parameter input dialog box]:

Press **[Up]** key to increase the number by 1

Press the **[Down]** key, the number to decrease by 1.

Press **[Right]** the cursor move one digit to the right.

Press **[Left]** the cursor move one digit to left.

Press **[MENU/OK]** key to confirm

[Storage inquiry dialog box]:

Press **[right]** key, do not store data or options, go back to the menu item previous **[Storage inquiry dialog box]**.

Press the **[left]** key to store data or options, go back to the menu item previous **[Storage inquiry dialog box]**.

3.3 Functional operation details

3.3.1 flow setting :

Press **[VALVE]** key to enter the flow setting interface

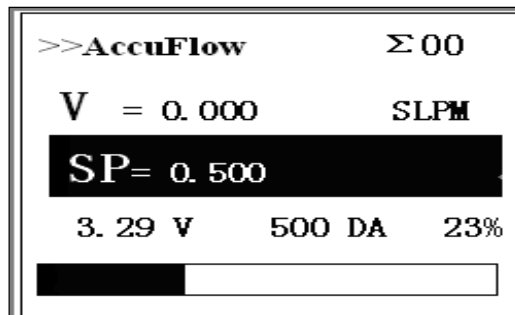

Press **[Up]**key to increase flow setting, press **[Down]**key to decrease flow setting, press **[Left]** key to set flow to 0, press **[Right]** key to set the flow to full scale. Press the **[VALVE]** key to save and return monitor status.

3.3.2 Start/stop flow accumulation:

(1) Under **[Monitoring value display status]** Status, press **[MENU/OK]** to enter **[Menu display status]**

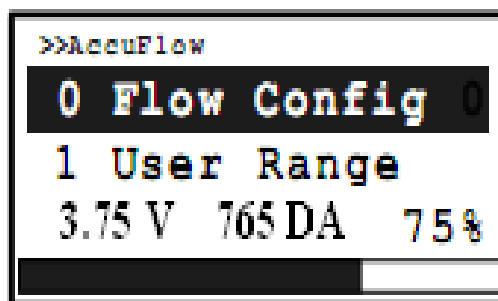

(2) Press the **[MENU/OK]** key shows that enter submenu of Usage Flow Setting
If the cumulative function is stopped, the following screen is displayed.

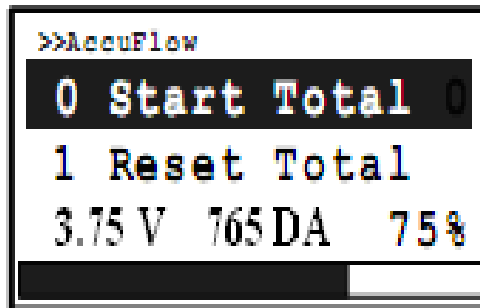

If the cumulative flow meter has been started, the following screen is displayed

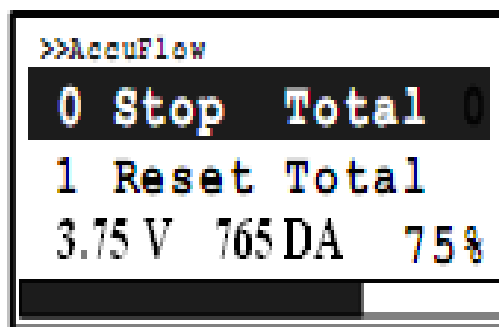

At present, press the [MENU/OK] key to enter the [Storage inquiry dialog box]

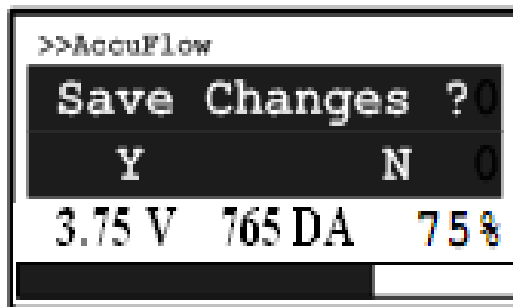

At this point, press the [Left] key to modify and store. Press the [right] key to exit to the previous menu.

3.3.3 Clear flow accumulative value

- (1) Under [Monitoring value display status] Status, press [MENU/OK]key to enter [Menu display status]

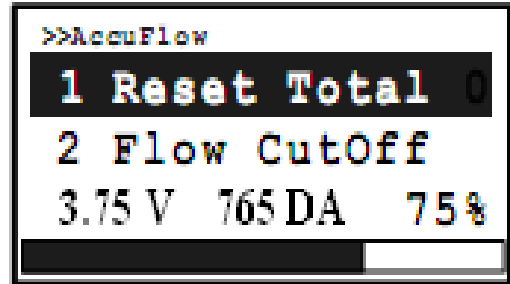
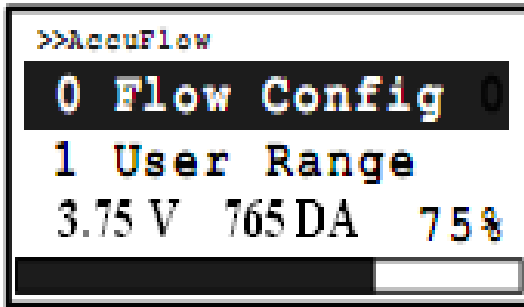

(2) Press [MENU/OK] key to enter the flow setting submenu, press [right] key to make the menu item “1 Reset Total” in focus;

(3) Press the [MENU/OK] key to display that into the [Storage inquiry dialog box]

(4) Press [Left] key to modify and store. Press [Right] to exit to the previous menu

3.3.4 Small flow signal removal

(1) Under [Monitoring value display status] Status, press [MENU/OK] to enter [Menu display status]

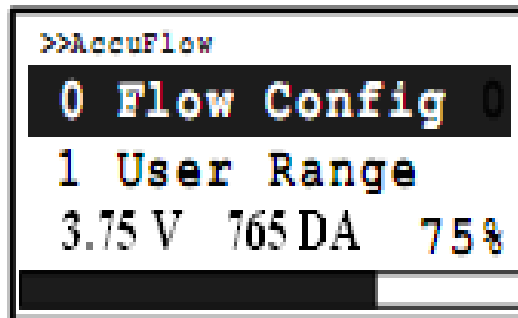

(2) Press [MENU/OK] key to enter the flow setting submenu, press [right] to make the menu item “2 Flow Cut Off” in focus;

(3) Press [MENU/OK] key to enter the [Parameter input dialog box], then input the required data

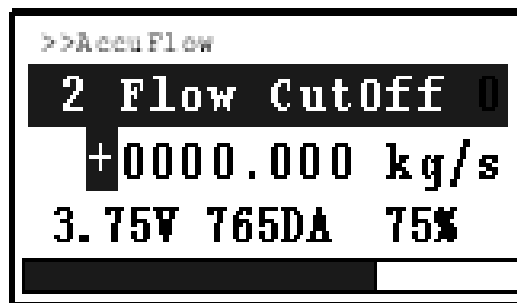

(4) After modifying the last character, press the [MENU/OK] key to enter the [Menu display status]



At this point, press the [Left] key to store the data and press the [Right] key to give up storage and return to the previous menu.

3.3.5 flow coefficient:

(1) Under [Monitoring value display status]Status, press [MENU/OK]key to enter [Menu Display Status].

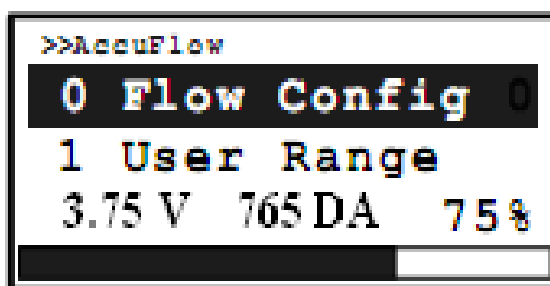

(2) Press the [MENU/OK] key to display that enter the flow settings submenu, press the [Left] key to make the "3 Coefficient" in the focus state



(3) Press [MENU/OK] key to enter the [Parameter input dialog box], then input the required data

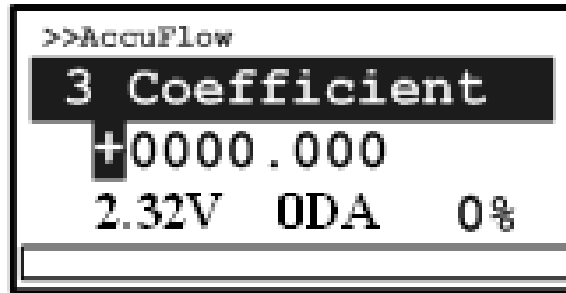

- (4) After modifying the last character, press the [MENU/OK] key to enter the [Storage inquiry dialog box]

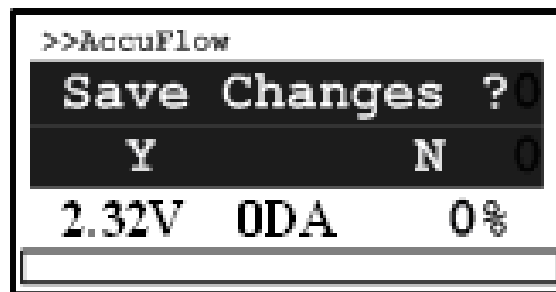

At this point, press the [Left] key to store the data and press the [Right] key to give up storage and return to the previous menu.

3.3.6 Zero setting of flow

- (1) Under [Monitoring value display status]Status, press [MENU/OK]key to enter [Menu Display Status].

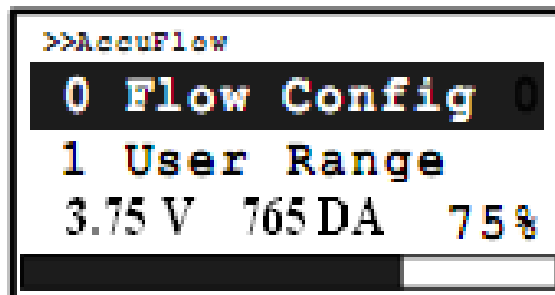

- (2) Press [Right]key to make the menu item "2 Zero Offset" in focus;

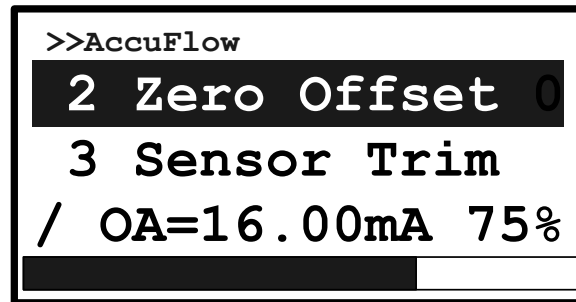

(3) Press [MENU/OK] key to display the zero setting submenu of the installation position; make the menu item “1 Set Zero” in focus; press the [MENU/OK] key to perform (5) operation to set up the zero point of the flow;

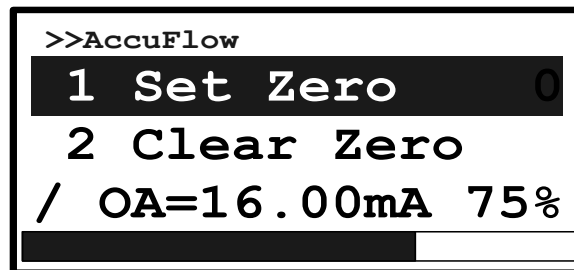

(4) Press the [Right] key to make the menu item “2 Clear Zero” in focus; this is the operation to cancel set zero of flow;

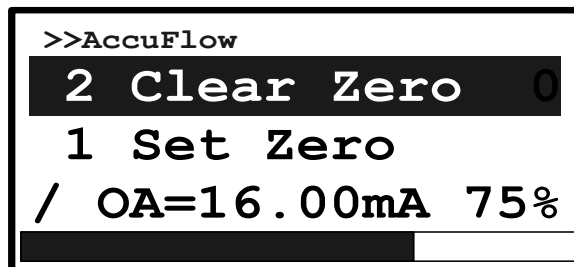

(5) Press [MENU/OK] to display enter the [Storage inquiry dialog box]

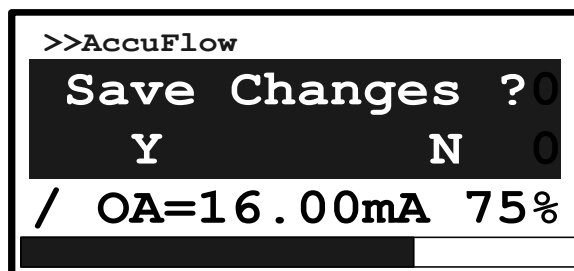

At this point, press the [Left] key to store the zero value, and press the [Right] key to give up storage and return to the previous menu.

3.3.7 Device polling address setting:

(1)) Under [Monitoring value display status]Status, press [MENU/OK] to enter [Menu Display Status].

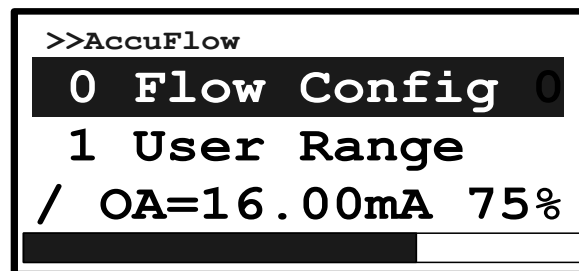

(2) Press [right]key to make the menu item "6 Hart Address" in the focus state

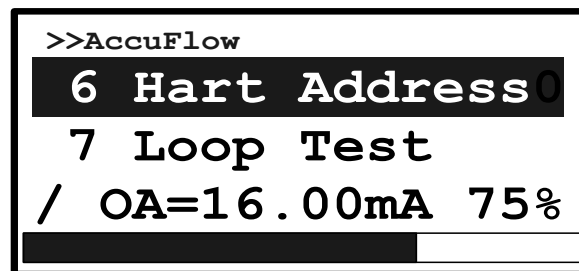

(3) Press [MENU/OK] key to enter the Hart address setting submenu. The third line shows the current polling address.

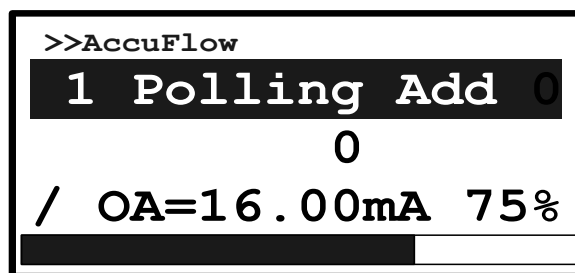

(4) Press [MENU/OK] key to enter the [Parameter input dialog box] and enter the expected value (address range 0~31).

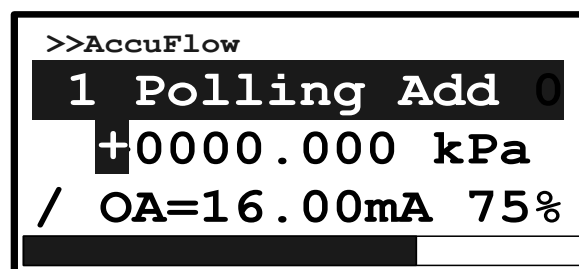

(5) After modifying the last character, press the [MENU/OK] key to enter the [Storage inquiry dialog box]

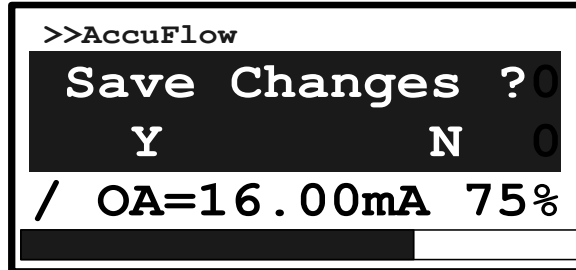

At this point, press the [Left] key to store the data and press the [Right] key to give up storage and return to the previous menu.

3.3.8 Loop output test:

(1) Under [Monitoring value display status]Status, press [MENU/OK] key to enter [Menu Display Status]

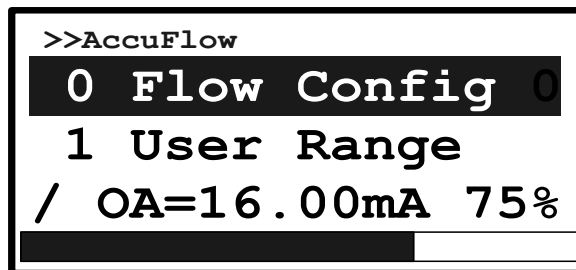

(2) Press [Right]key to make the menu item "7 Loop Test" in focus;

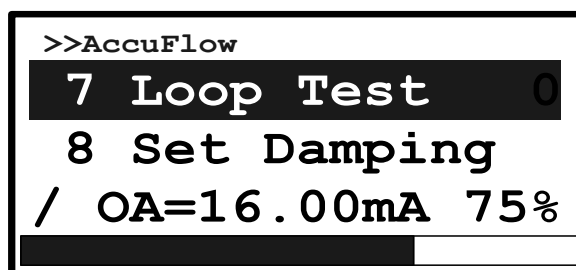

(3) Press [MENU/OK] key to enter the loop test submenu;

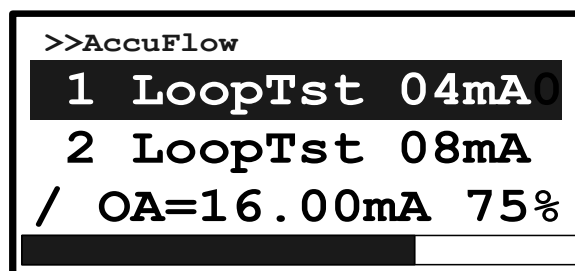

Note: at this time the instrument output current is locked at 4mA.

(4) Press [Right] key, scroll menu item, can make the output current of the instrument locked to the corresponding value; (for example, the lock value is 16, as shown below)

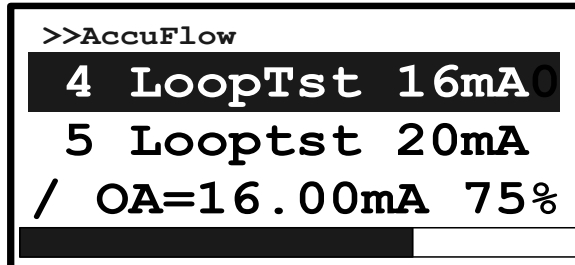

Under the loop test menu status, press the [Left] key to exit the loop test and return to the previous menu, and the meter current returns to automatic.

3.3.9 Control mode conversion:

(1) Under [Monitoring value display status]Status, press [MENU/OK] key to enter [Menu Display Status];

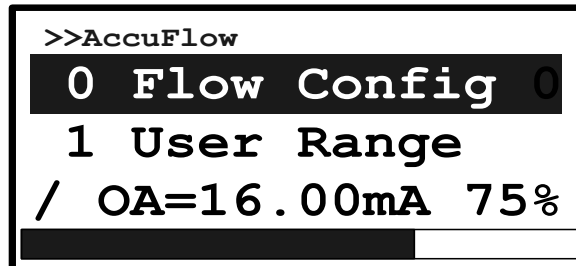

(2) Press [MENU/OK]key ,enter flow setting sub-menu, press [right]key to make "4 Caculate Mode" in the focus state

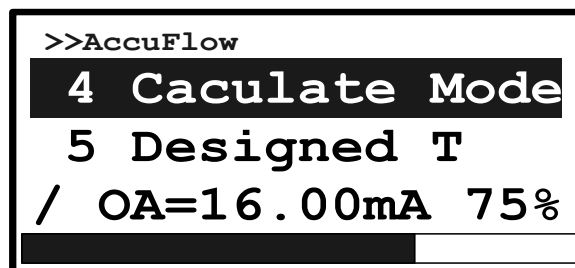

(3) Press [MENU/OK] key to enter the submenu of operation mode selection;

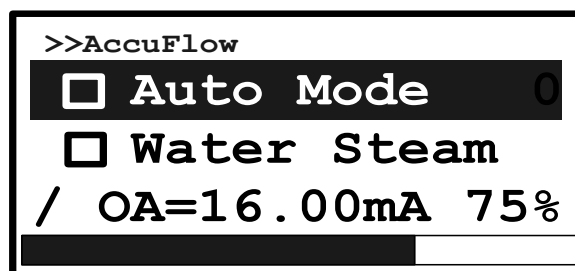

(4) Press [Right] key to scroll through the options. When “Analog Input” is selected, it is the external analog signal control mode; when “Local/RS485” is selected, it is local key operation control or RS485 communication control;

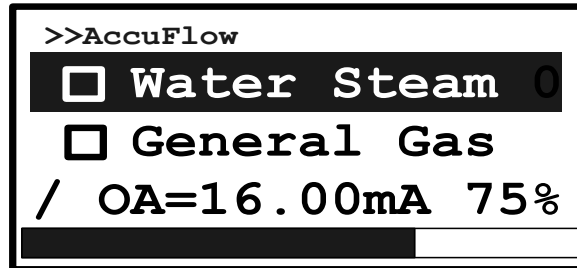

(5) At this point, press the [MENU/OK] key to enter the [Storage inquiry dialog box].

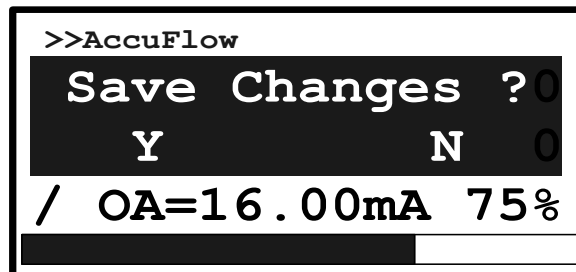

Press [left] key to store data, press [right] key, give up storage, and return to the previous menu. if stored, and the box before the selected item is filled with dot.

3.3.10 Set the output damping value:

(1) Under [Monitoring value display status]Status, press [MENU/OK] key to enter [Menu Display Status];

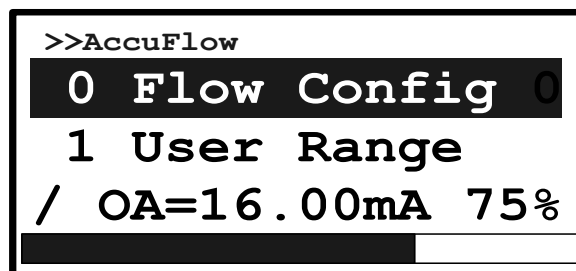

(2) Press the [right]key to make the menu item "8 Set Damping" in focus.;

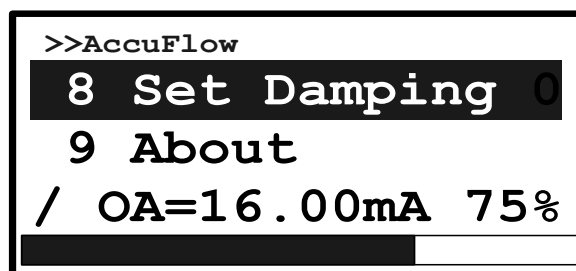

(3) Press [MENU/OK] key, will enter the damping setting submenu, and the third line shows the current damping value;

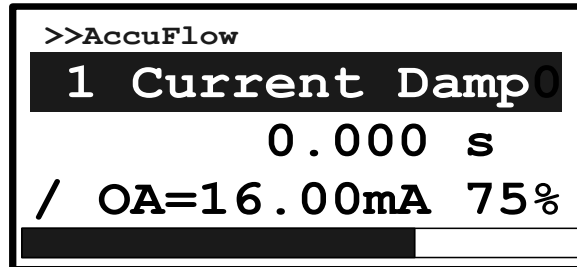

(4) Press [MENU/OK] key to enter the [Parameter input dialog box], then enter the expected value (0~254);

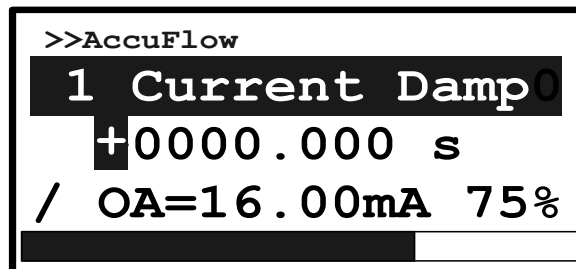

(5) After modifying the last character, press the [MENU/OK] key to enter the [Storage inquiry dialog box];

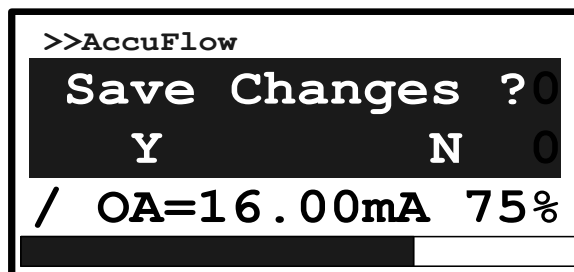

At this point, press [left]key to store data, press [right] key, give up storage, and return to the previous menu.

4.Attention

4.1 Adding filter

The use of gas must be purified, avoid dust, liquids and oil. If necessary, install a filter. If a liquid source bottle is connected to the outlet of the flowmeter, install a one-way valve at the outlet of the flowmeter to prevent the liquid from flowing back and damaging the flowmeter.

4.2 Use for corrosive gases

The materials used for the flowmeter channel are: SUS 316L (00Cr17Ni14Mo2), SUS 417J1 (00Cr30Mo2), fluorine rubber and other corrosion resistant materials. It can be used to control general corrosiveness when other users use corrosive gas and organic solvent gas under the condition that the user's system has no soda, low leakage, diligence, and good use. It should be stated at the time of ordering. With special corrosive gases, all sealing materials must be changed accordingly

4.3 Installation position

The controller is best installed to maintain the level of the installation surface, but not particularly sensitive to the location, can be installed at any position, if the zero offset is found when installing in non-horizontal position, you can adjust the zero point after work.

4.4 Valve sealing

The valve of the mass flow controller is a regulating valve, not a shut-off valve, and cannot be used as a shut-off valve. The user should be equipped with a shut-off valve. In particular, when users use corrosive gases, a shut-off valve should normally be added to the inlet and outlet ports of the mass flow controller to ensure work safety. After long-term work, if the leakage rate of the controller valve port is within 2%F.S, it is normal. If the leak is greater than 2% of full scale, service should be performed.

4.5 Calibration and conversion of different gases

The flow meter is usually calibrated by nitrogen (N₂). If other gas calibration is required, special orders should be made with the salesperson when ordering.

When users of flow controllers calibrated with nitrogen use other gases, they can be converted by the conversion factor of the appendix.

5.General anomaly judgment and treatment

Phenomenon	Possible reasons	treatment methods
No air flow after power on	The air source is not open and the air is not accessible	Connect the gas source and open the gas path
	Didn't set the target flow	Reference detailed operation 3.4
	Filter clogging	Change the filter
	Control valve failure	Check the valve
	Circuit failure	Repair circuit
	Zero deviation	Reference detailed operation 3.4
Flow control unstable	Sensor failure	Change sensor
	Circuit failure	Repair circuit
	Valve pollution	Clean the valve,change the seal
	The pressure of the gas source is too low or unstable.	Improve gas source pressure and stabilize gas source pressure
When the valve is closed, there is still a larger flow.	Control valve failure	Check the valve
	High inlet pressure	Reduce inlet pressure
	Channel clogging	Clean MFC channel
Display can't reach full scale	Set target flow below full scale	Check the set target flow
	Other circuit faults	Repair circuit
Zero instability at no flow	Circuit faults	Repair circuit
	Sensor failure	Change sensor

6. Guarantee, warranty and service

6.1 Product assurance and warranty

6.1.1 The MFC/MFM products produced by our company are within two years of shipment. If the user is used according to the instructions, and the product has not suffered physical damage, pollution, modification or refurbishment, we guarantee the quality of the material, processing and performance of the product. If there is a problem, the product will be repaired free of charge.

6.1.2 After receiving the goods, the user has the responsibility to check and check the goods and to inform the Sales Department of the company in a timely manner by fax, telephone or e-mail.

6.1.3 During the warranty period, the product must be repaired by the company or authorized service center, otherwise, the warranty of the product is invalid.

6.1.4 The maintenance is free of charge within one year's warranty. If the warranty is over, users will be informed of the components and maintenance costs that need to be replaced before maintenance. After repair, the repair part is guaranteed within 90 days. The warranty includes vulnerable parts (such as Teflon or seal ring).

6.1.5 Users who have used toxic, contaminated or corrosive gas products will not be responsible for repair or warranty if they are not shown to clear the pollution and clean the treatment.

6.2 Requirements for the use of warranty

6.2.1 The gas must be clean and free of particulate matter and liquid. This requires the installation of <30 M filter in the upstream gas path of MFC/MFM.

6.2.2 The input gas pressure must conform to the product's withstand voltage standard and should not exceed the maximum pressure required by the product.

6.2.3 The gas used in the product must be compatible with the sealing material selected by the user. The user is responsible for using each gas according to the applicable safety regulations. Incorrect use of the product will make the warranty invalid. The damage caused by incorrect use can not be attributed to the company.

6.2.4 Requirements for electronic circuits: we must carefully connect the wiring of the system according to the regulations. Incorrect wiring will cause permanent damage to the internal circuit boards of the products. MFC power supply needs high voltage interference less than 5mV voltage regulator.

6.2.5 Connection of gas path: the sealing fittings must be carefully installed to ensure that all sealing pipes are inspected individually and without scratches.

6.2.6 It is forbidden to disassemble MFC/MFM on its own. If the damage is caused by self dismantling, the warranty promised by the company is invalid.

Appendix: Gas flow conversion factor

Gas	code	specific heat(Calorie /g°C)	Density (g/L0°C)	Change rate
Air	008	0.2400	1.2930	1.006
Ar	004	0.1250	1.7837	1.415
AsH ₃	035	0.1168	3.4780	0.673
BBr ₃	079	0.0647	11.1800	0.378
BCl ₃	070	0.1217	5.2270	0.430
BF ₃	048	0.1779	3.0250	0.508
B ₂ H ₆	058	0.5020	1.2350	0.441
CCl ₄	101	0.1297	6.8600	0.307
CF ₄	063	0.1659	3.9636	0.420
CH ₄	028	0.5318	0.7150	0.719
C ₂ H ₂	042	0.4049	1.1620	0.581
C ₂ H ₄	038	0.3658	1.2510	0.598
C ₂ H ₆	054	0.4241	1.3420	0.481
C ₃ H ₄	068	0.3633	1.7870	0.421
C ₃ H ₆	069	0.3659	1.8770	0.398
C ₃ H ₈	089	0.3990	1.9670	0.348
C ₄ H ₆	093	0.3515	2.4130	0.322
C ₄ H ₈	104	0.3723	2.5030	0.294
C ₄ H ₁₀	111	0.4130	2.5930	0.255
C ₅ H ₁₂	240	0.3916	3.2190	0.217
CH ₃ OH	176	0.3277	1.4300	0.584
C ₂ H ₆ O	136	0.3398	2.0550	0.392
C ₂ H ₃ Cl ₃	112	0.1654	5.9500	0.278
CO	009	0.2488	1.2500	1.000
CO ₂	025	0.2017	1.9640	0.737
C ₂ N ₂	059	0.2608	2.3220	0.452
Cl ₂	019	0.1145	3.1630	0.858
D ₂	014	1.7325	0.1798	0.998
F ₂	018	0.1970	1.6950	0.931
GeCl ₄	113	0.1072	9.5650	0.267
GeH ₄	043	0.1405	3.4180	0.569
H ₂	007	3.4224	0.0899	1.010
HBr	010	0.0861	3.6100	1.000
HCl	011	0.1911	1.6270	1.000
HF	012	0.3482	0.8930	1.000
HI	017	0.0545	5.7070	0.999
H ₂ S	022	0.2278	1.5200	0.844
He	001	1.2418	0.1786	1.415

Kr	005	0.0593	3.7390	1.415
N ₂	013	0.2468	1.2500	1.000
Ne	002	0.2464	0.9000	1.415
NH ₃	029	0.5005	0.7600	0.719
NO	016	0.2378	1.3390	0.976
NO ₂	026	0.1923	2.0520	0.741
N ₂ O	027	0.2098	1.9640	0.709
O ₂	015	0.2196	1.4270	0.992
PCl ₃	193	0.1247	6.1270	0.358
PH ₃	031	0.2610	1.5170	0.691
PF ₅	143	0.1611	5.6200	0.302
POCl ₃	102	0.1324	6.8450	0.302
SiCl ₄	108	0.1270	7.5847	0.284
SiF ₄	088	0.1692	4.6430	0.348
SiH ₄	039	0.3189	1.4330	0.599
SiH ₂ Cl ₂	067	0.1472	4.5060	0.412
SiHCl ₃	147	0.1332	6.0430	0.340
SF ₆	110	0.1588	6.5160	0.264
SO ₂	032	0.1489	2.8580	0.687
TiCl ₄	114	0.1572	8.4650	0.206
WF ₆	121	0.0956	13.2900	0.215
Xe	006	0.0397	5.8580	1.415